

## TRACE GAS MONITOR

GA-360E Series



### *The two-in-one high-sensitivity analyzer*

- **NDIR absorptiometry with unique cross-flow modulation technique.**
- **Designed to measure impurities in semiconductor industry bulk gas (N<sub>2</sub>) and other high-purity gases such as He, O<sub>2</sub>, Air and Ar.**
- **Simultaneous and continuous measurement of any two components among CO, CO<sub>2</sub> and CH<sub>4</sub>.**
- **Compact and lightweight, fits in a standard 19-inch rack.**

HORIBA is a worldwide leader in non-dispersive infrared (NDIR) technology and a major NDIR analyzer manufacturer. The heart of the GA-360E Trace Gas Monitor is the multinationally accepted, field-proven, cross-flow modulated HORIBA NDIR analyzer.

#### **New concept in trace gas monitors**

The GA-360E represents a new concept in trace gas monitors. Designed to eliminate routine calibration cycles and to provide long-term stable measurement and continuous unattended operation, it furnishes reliable concentration

data under such conditions. Every element of the monitor has been selected to offer the ultimate in reliability and accuracy. Solid-state modular electronics ensure optimum performance and minimum maintenance.

#### **Line of two-component versions**

The GA-360E is available in two component versions for measuring any two-component combination of CO, CO<sub>2</sub> and CH<sub>4</sub> specified by the customer. Simultaneous measurement of two different components is made possible by linking two detectors to the main unit via a single sample line.

## Principle

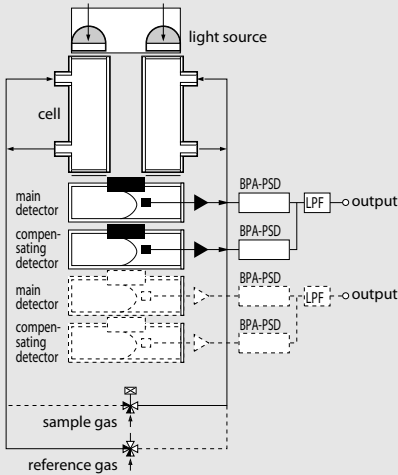

BPA-PSD: Brand Pass Amplifier  
Phase Sensitive Detection  
LPF: Low Pass Filter

An infrared beam in the analyzer unit passes through the cell to the detector. During measurement, the solenoid valves alternately direct the sample gas and the reference gas (supplied by the customer) to the cells of the analyzer. The presence of CO, CO<sub>2</sub> and/or CH<sub>4</sub> in the sample gas generates a difference in the intensity of the light reaching the detector when the cell is filled with sample gas from when it is filled with reference gas. This difference causes a metallic membrane in the detector to move back and forth in accordance with the alternating gas flow (cross-flow modulation). The analyzer requires neither an optical chopper nor optical adjustment. Furthermore, this technique virtually eliminates zero drift and greatly enhances analyzer sensitivity. Zero and span calibrations are performed by introducing standard gases.

## Flow Schematic

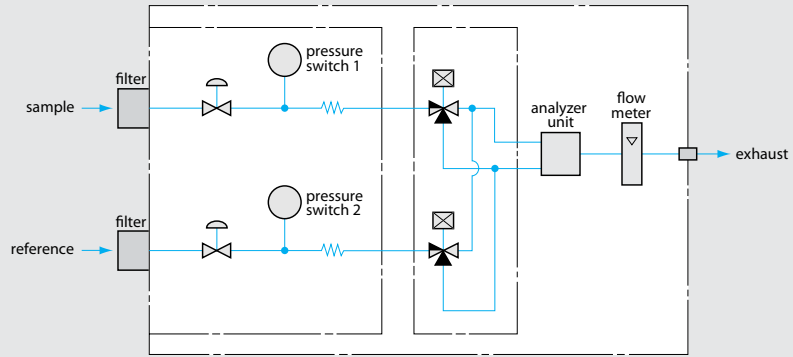

## SPECIFICATIONS

**Model name:** GA-360E

**Principle:** Non-dispersive infrared absorption (NDIR)

**Application:** CO, CO<sub>2</sub> and CH<sub>4</sub> in N<sub>2</sub>, He, O<sub>2</sub>, Air, and Ar.

**Range:** 0 – 1/2/5/10 ppm

**Min. detection sensitivity:** 0.01 ppm (1 sigma)

**Repeatability:** Within ±2% F.S.

**Linearity:** Within ±2% F.S.

**Zero drift:** Within ±0.02 ppm/day  
Within ±0.03 ppm/7days

**Span drift:** Within ±2% F.S./day  
Within ±3% F.S./7days

**Response (T<sub>90</sub>):** Less than 180 sec.

**Display:** Measured value, range, alarm

**Reference gas:** N<sub>2</sub>, He, O<sub>2</sub>, Air, and Ar.

**Alarm:** Flow, chopper, power down

**Output:** 0 – 1 V, 10V, 4– 20 mA

**Power supply:** AC 100 V, 115 V, 220 V (to be specified)

**Remarks:**

- 1) The two-component version measures any two of the above three components specified by the customer.
- 2) Reference gas is to be supplied by the customer.

## Dimensional Outlines Unit: mm (in)

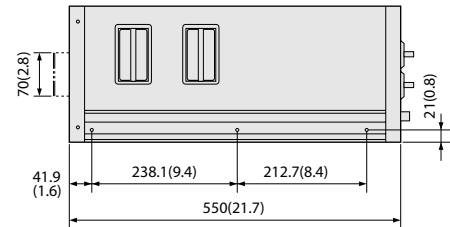
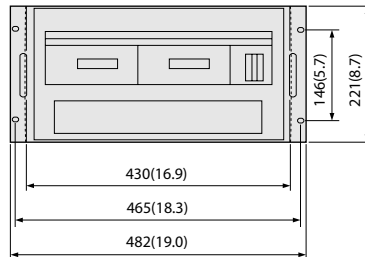

# HORIBA

<http://www.horiba.com> e-mail: [info@horiba.co.id](mailto:info@horiba.co.id)



## ETA Associates

119 Foster Street, Bldg #6 • Peabody, MA 01960

Tel: (978) 532-1330 • Fax: (978) 532 7325 • [www.ETAassociates.com](http://www.ETAassociates.com) • [eta@ETAAssociates.com](mailto:eta@ETAAssociates.com)