

## WDG-INSITU FLUE GAS OXYGEN ANALYZER

Direct-sensing insitu probe suitable for applications where the flue gas temperature does not exceed 1250°F (677°C) and where combustibles measurement is not required. Completely field serviceable.

### SENSOR

**Principle of Operation:** Zirconium oxide for net oxygen measurement.

**Output Range:** Oxygen: From 0-1% to 0-100%

**Accuracy:** ±1% of measured value or ±0.05% oxygen, whichever is greater

**Response:** 63% of a step change < 20 seconds.

**Drift:** < 0.1% of cell output per month (< 0.005% O<sub>2</sub> per month with 2% O<sub>2</sub> applied)

**Linearity:** ±1% of output span

**Repeatability:** ±1% of output span

**Max. Flue Gas Temperature:** 1250°F (677°C). Probe material highly corrosion resistant.

**Sample Pressure:** ± 10 in. water gauge

**Environment:**

Ambient Temp.: -5 to 160°F (-20 to 71°C)  
Relative Humidity: 10% to 90%, non-condensing

**Enclosure:** UL type (NEMA 4X) standard. Optional explosion-proof and purged versions available. (Purged version for subatmospheric process pressure only.)

**Power Requirements:** 115 VAC, ± 10%, 47-63 Hz; 230 VAC, ± 10%, 47-63 Hz; 150 VA max.

**Calibration Gas Requirements:** Use all calibration gases @ 10 psig, 3 to 6 scfh (0.70 kg/cm<sup>2</sup>, 1.41 to 2.82 L/min.)

O<sub>2</sub> Span Gas: Air or from 1.0% to 100% O<sub>2</sub>, balance N<sub>2</sub>

O<sub>2</sub> Zero Gas: 2% or from 0.1 to 10% O<sub>2</sub>, balance N<sub>2</sub>



WDG-INSITU Probe



Series 2000 Control Unit

### SERIES 2000 CONTROL UNIT

**Display:** Four-line x 20-character vacuum fluorescent. Displays combinations of oxygen, time and date, cell temperature, user-programmable text, thermocouple mV or cell mV. Password protection, programmable pressure compensation and context sensitive help are also provided.

**Analog Output:** Two isolated linear current outputs. Select O<sub>2</sub>, cell temperature, thermocouple mV or cell mV. Each output can be 4-20 mA, 0-20 mA, 20-4 mA or 20-0 mA and is fully scalable. Hold or track during calibration and select degree of damping. Maximum load 1200 ohms.

**Alarms:** Two independent oxygen alarms, each high- or low-selectable. One alarm can be assigned as oxygen, calibrate or verify. Set relays to energize or de-energize on alarm.

**Contact Rating:** 1A, 30V max. non-inductive load, AC or DC

**Diagnostics:** Watchdog timer and service alarms. System test for A/D, RAM, EEPROM and keypad. Display line 4 reserved for full-text error and diagnostic messages. Twenty-entry event log.

**Communications:** RS-485 2-way addressable.

**Environment:**

Ambient Temp.: 14 to 122°F (-10 to 50°C)  
Relative Humidity: 10% to 80%, non-condensing

**Enclosure:** Standard weatherproof NEMA 4 (IP 56) wall/panel mount. Optional GP (General Purpose) wall mount, GP 19" rack mount, GP panel mount, or stainless steel weatherproof NEMA 4X (IP 56) wall/panel mount. All are UL Listed for NEC Class I, Division 2 areas. Purged and explosion-proof versions also available.

**Calibration:** Oxygen cell lifetime extender. Calibrate or verify calibration. Store last calibration and verification data. Selectable calibration gas run time and process recovery time. Timed automatic calibration with optional Remote Calibration Unit.

**Power Requirements:** Nominal 115-230 VAC ±10%, 47-63 Hz; 75 VA max.

**System Compliance:**

EMC Directive 2004/108/EC  
Low Voltage Directive 73/23/EEC

# WDG-INSITU ANALYZER

## SENSOR

INCHES  
CM

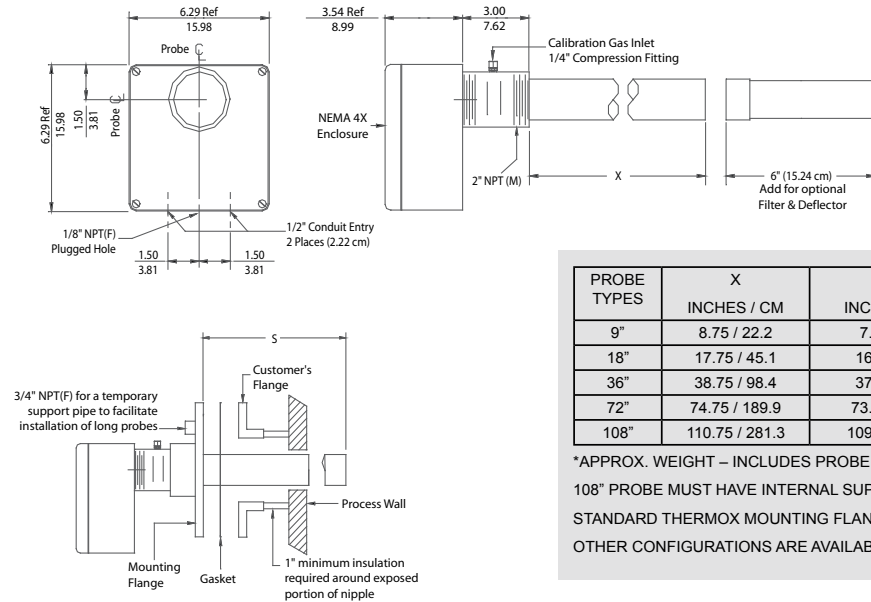

PROBE TYPES	X INCHES / CM	S INCHES / CM	WEIGHT* LB / KG
9"	8.75 / 22.2	7.0 / 17.8	15 / 6.8
18"	17.75 / 45.1	16.0 / 40.6	20 / 9.1
36"	38.75 / 98.4	37.0 / 94.0	25 / 11.3
72"	74.75 / 189.9	73.0 / 185.4	40 / 18.1
108"	110.75 / 281.3	109.0 / 276.8	50 / 22.7

\*APPROX. WEIGHT – INCLUDES PROBE + FLANGE.  
 108" PROBE MUST HAVE INTERNAL SUPPORT PROVIDED BY CUSTOMER.  
 STANDARD THERMOX MOUNTING FLANGES: 3" – 300# AND 4" – 150#.  
 OTHER CONFIGURATIONS ARE AVAILABLE UPON REQUEST.

## REMOTE CALIBRATION UNIT

ENCLOSURE NEMA 4X, APPROX. WEIGHT: 8 LB (3.6 KG)

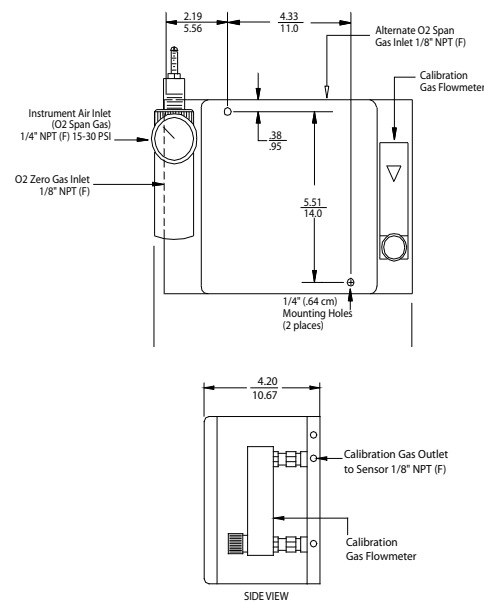

## CONTROL UNIT

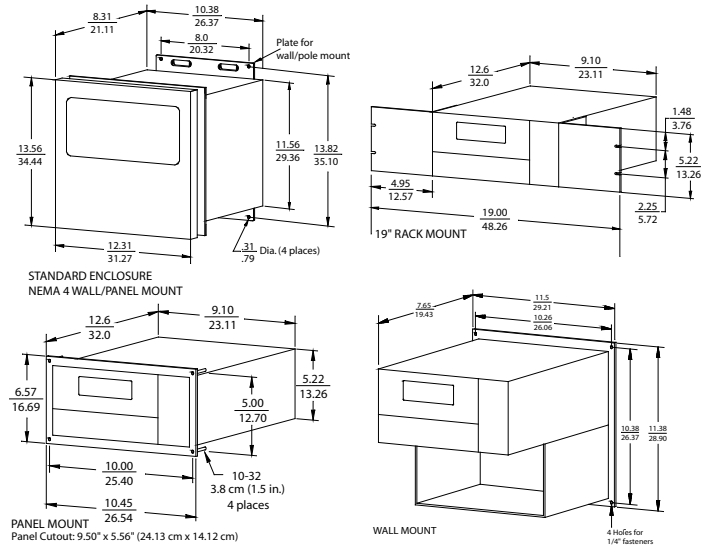

APPROX. WEIGHTS  
 NEMA 4 WALL/PANEL MOUNT: 28 LB (12.7 KG)  
 19" RACK MOUNT: 14 LB (6.35 KG)  
 PANEL MOUNT: 14 LB (6.35 KG)  
 WALL MOUNT: 14 LB (6.35 KG)

- NOTES:
1. All static performance characteristics are with operating variables constant.
  2. System accuracy referenced to 0.1 to 10% calibrated range.
  3. Response is to calibration gas.

**AMETEK**<sup>®</sup>  
 PROCESS INSTRUMENTS  
 150 Freeport Road, Pittsburgh, PA 15238  
 Ph. +1-412-828-9040, Fax +1-412-826-0399  
 www.thermox.com



© 2006, by AMETEK, Inc.  
 All rights reserved. Printed in the U.S.A.  
 P300 (8/07)

One of a family of innovative process analyzer solutions from AMETEK Process Instruments.  
 Specifications subject to change without notice.

**ETA Associates**  
 119 Foster Street, Bldg #6  
 Peabody, MA 01960  
 Tel: (978) 532-1330  
 Fax: (978) 532-7325  
 www.ETAassociates.com  
 eta@ETAassociates.com

THERMOX<sup>®</sup>