

The Badger Meter Series 200 flow sensors feature a six bladed impeller design with a proprietary non-magnetic sensing mechanism. The forward swept impeller shape provides higher, more consistent torque and is less prone to be fouled by water borne debris. The forward curved shape coupled with the absence of magnetic drag provides improved operation and repeatability even at lower flow rates. This is especially true where the impeller is exposed to metallic or rust particles found in steel or iron pipes. As the liquid flow turns the impeller, a low impedance square wave signal is transmitted with a frequency proportional to the flow rate. The signal can travel up to 2000 feet between the flow sensor and the display unit without the need for amplification. All sensors except irrigation versions are supplied with 20 feet of 2-conductor 20 AWG shielded U.L. type PTLC 105°C cable.

MODEL 225BR AND 226BR/226SS SENSORS

The Model 225BR and 226BR/226SS sensors are used for flow measuring applications in most metallic or non-metallic pipes where it would be difficult to shut down or drain the line for installation or service. The Model 225 features a gate valve for isolation. The Model 226 uses a ball valve. If the pipe is to be hot tapped, the ball valve is recommended. The sensor mounts in a 2" NPT pipe saddle or Threadolet® for installation in pipe sizes from 3" to over 40". Positioning nuts on the three threaded retaining rods allow the sensor to be accurately positioned to a standard insertion depth of 1½" into the pipe. When this insertion depth is maintained, and there are at least 10 upstream and 5 downstream diameters of straight uninterrupted flow, an accuracy of +/-1% of full scale can be obtained between flow velocities of 0.5 to 30 feet/second. Each sensor is equipped with an isolation valve and pipe nipple to allow the sensor to be installed in a pressurized pipe. This is accomplished by first attaching a saddle or Threadolet® to the pipe and screwing the nipple and isolation valve into the saddle or Threadolet fitting. A hole is then drilled through the pipe using a commercial tapping machine. When completed, the tapping apparatus is removed, the isolation valve is closed, and the sensor is installed using a Model HTT Hot Tap Tool.

NOTE: that the overall length of the sensor tube is 18 inches (457mm), however, a clearance height of 35 inches (127mm) should be allowed for the fully extended length of the sensor tube outside the isolation valve.

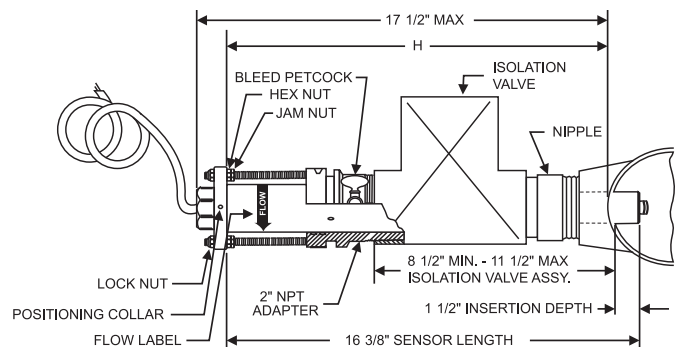

NOTE: ALL DIMENSIONS ARE FOR REFERENCE ONLY. TO REMOVE THE FLOW SENSOR THERE MUST BE 35" OF CLEARANCE ABOVE THE OUTSIDE WALL OF THE PIPE. A CUTTING TOOL MAY REQUIRE ADDITIONAL CLEARANCE.

Dimensions Models 225/226



Model HTT - Hot Tap Tool



APPROVED



SPECIFICATIONS

Wetted Materials for all sensors

—(see ordering matrix)

Sensor Sleeve and Hex Adapter for 225BR and 226BR

- Sleeve: Admiralty Brass, UNS C44300
- Hex Adapter: Valve Bronze, UNS C83600

Sensor Sleeve and Hex Adapter for 226SS

- 316 Series Stainless Steel

Temperature Ratings

- Standard Version: 221°F (105°C) continuous service
- Irrigation Electronics 150°F (66°C)

Pressure Ratings

	At 100°F
225BR	300 psi
226BR	400 psi
226SS	400 psi

Recommended Design Flow Range

- 0.5 to 30 ft/sec
- Initial detection below 0.3 ft/sec

Accuracy

- ± 1.0% of full scale over recommended design flow range
- ± 4.0% of reading within calibration range

Repeatability

- ± 0.3% of full scale over recommended design flow range

Linearity

- ± 0.2% of full scale over recommended design flow range

Transducer Excitation

- Quiescent current 600uA@8VDC to 35VDC max.
- Quiescent voltage (V_{high}) Supply Voltage -(600uA*Supply impedance)
- ON State (V_{Low}) Max. 1.2VDC@40mA current limit (15W+0.7VDC)



226SS

Example:	2	25	BR	00	0	5	-	0	2	1	1
STYLE											
Hot Tap Insert-Gate Valve		25									
Hot Tap Insert-Ball Valve		26									
MATERIAL											
Brass			BR								
Stainless Steel			SS								
SIZE											
Insert Style		00									
ELECTRONICS HOUSING											
PPS		0									
ELECTRONICS											
Magnetic					2						
FM/CSA Approved					4						
Standard					5						
IR-Irrigation					6						
O-RING											
Viton®						0					
EPDM						1					
Kalrez®						2					
Food Grade Silicon						3					
Neoprene						4					
Chemraz®						5					
Teflon® Encapsulated Viton®						6					
Teflon Encapsulated Silicone						7					
Buna N						8					
SHAFT											
Zirconia Ceramic							0				
Hastalloy® C							1				
Tungsten Carbide							2				
Titanium							3				
Monel®							5				
316 Stainless Steel							6				
Tantalum							7				
IMPELLER											
Nylon								1			
Tefzel®								2			
BEARING											
Pennlon®									1		
Tefzel										2	
Teflon											3

Series 200 HotTap Matrix (sizes 3" and up)

Output Frequency

- 3.2 Hz to 200 Hz

Output Pulse Width

- 5 msec ±25%

Electrical Cable for Standard Sensor Electronics

- 20 feet of 2-conductor 20 AWG shielded U.L. type PTLC wire provided for connection to display or analog transmitter unit. Rated to 105°C. May be extended to a maximum of 2000 feet with similar cable and insulation appropriate for application.

Electrical Cable for IR Sensor Electronics

- 48 inches of U.L. Style 116666 copper solid AWG 18 wire with direct burial insulation. Rated to 105°C.

Badger® and Data Industrial® is a registered trademark of Badger Meter, Inc.
 Pennlon® is a registered trademark of the Dixon Corporation.
 Hastalloy® is a registered trademark of The Haynes Stellite Company.
 Monel® is a registered trademark of Inco Alloys International, Inc.
 Teflon®, Tefzel® and Viton® are registered trademarks of DePont Dow Elastomers.
 Chemraz® is a registered trademark of Green Tweed.
 Threadolet® is a registered trademark of Bonney Forge & Tool Works Corporation.

ETA Associates

119 Foster Street, Bldg #6
 Peabody, MA 01960
 Tel: (978) 532-1330
 Fax: (978) 532-7325
 www.ETAassociates.com
 eta@ETAassociates.com



Due to continuous research, product improvements and enhancements, Badger Meter reserves the right to change product or system specifications without notice, except to the extent an outstanding contractual obligation exists.



BadgerMeter, Inc.

P.O. Box 581390, Tulsa, Oklahoma 74158
 (918) 836-8411 / Fax: (918) 832-9962
 www.badgermeter.com