

The Badger Meter Series 200 flow sensors feature a six bladed impeller design with a proprietary non-magnetic sensing mechanism. The forward swept impeller shape provides higher, more consistent torque and is less prone to be fouled by water borne debris. The forward curved shape coupled with the absence of magnetic drag provides improved operation and repeatability even at lower flow rates. This is especially true where the impeller is exposed to metallic or rust particles found in steel or iron pipes. As the liquid flow turns the impeller, a low impedance square wave signal is transmitted with a frequency proportional to the flow rate. The signal can travel up to 2000 feet between the flow sensor and the display unit without the need for amplification. All sensors except irrigation versions are supplied with 20 feet of Belden type 9320 two conductor shielded cable.

**MODEL 220BR (BRASS) AND 220SS (STAINLESS STEEL) SENSOR**

The Badger® Model 220BR and 220SS sensors are used in most general flow measuring applications in metallic or non-metallic pipes. The sensor mounts in a 2" NPT pipe saddle or Threadolet® for installation in pipe sizes from 3" to over 40". Positioning nuts on the three threaded retaining rods allow the sensor to be accurately positioned to a standard insertion depth of 1½" into the pipe. When this insertion depth is maintained, and there is at least 10 upstream and 5 downstream diameters of straight uninterrupted flow, an accuracy of +/-1% of full scale can be obtained from flow velocities of 0.5 to 30 feet/second (± 4.0% of reading within calibration range).

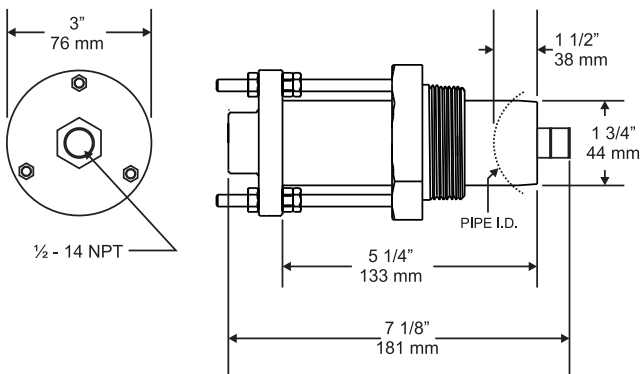

**Dimensions Model 220BR, 220SS**



**Model 220BR (Brass) & 220SS (Stainless Steel) Sensor**



**Model 220PVS**

**MODEL 220PVS**

The Badger Meter 220PVS flow sensor is an insertion style flow sensor will all wetted parts constructed of non-metallic materials. These sensors are designed for service in corrosive liquids. The metallic trim, in non-wetted areas, is 316 stainless steel. The sensor mounts in a 2" NPT thread and may be attached to the pipe with a saddle or other types of mounting hardware.

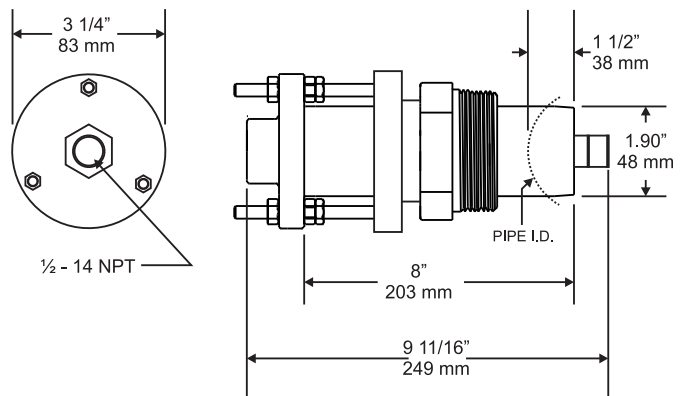

**Dimensions Model 220PVS**



**SPECIFICATIONS**

**Wetted Materials for all sensors**

- (see ordering matrix)

**Sensor Sleeve and Hex Adapter for 220BR**

- Sleeve: Admiralty Brass, UNS C44300;  
Hex Adapter: Valve Bronze, UNS C83600

**Sensor Sleeve and Hex Adapter for 220SS**

- 316 Series Stainless Steel

**Temperature Ratings**

- Standard Version:  
221°F (105°C) continuous service
- Irrigation Version:  
150°F (66°C) continuous service
- PVC Version:  
140°F (60°C) continuous service

**Pressure Ratings**

Metallic Sensor	<u>At 100°F</u>
220BR	400 psi
220SS	400 psi

Plastic Sensor	<u>At 100°F</u>
220PVS	100 psi

**Recommended Design Flow Range**

- 0.5 to 30 ft/sec
- Initial detection below 0.3 ft/sec

**Accuracy**

- ± 1.0% of full scale over recommended design flow range
- ± 4.0% of reading within calibration range

**Repeatability**

- ± 0.3% of full scale over recommended design flow range

**Linearity**

- ± 0.2% of full scale over recommended design flow range

**Transducer Excitation**

- Quiescent current 600uA@8VDC to 35VDC max.
- Quiescent voltage ( $V_{high}$ )  
Supply Voltage  $-(600uA * \text{Supply impedance})$
- ON State ( $V_{Low}$ ) Max. 1.2VDC@40mA current limit (15W+0.7VDC)

**Output Frequency**

- 3.2 Hz to 200 Hz

**Output Pulse Width**

- 5 msec ±25%

Example: 2   20   BR   00   0   5   -   1   2   1   1	
STYLE	Short Insert 20
MATERIAL	Brass BR Stainless Steel SS PVC Sleeve w/Stainless Steel Trim PVS
SIZE	Insert Style 00
ELECTRONICS HOUSING	PPS 0
ELECTRONICS	Magnetic 2 FM/CSA Approved 4 Standard 5 IR-Irrigation 6
O-RING	Viton® 0 EPDM 1 Kalrez® 2 Food Grade Silicon 3 Neoprene 4 Chemraz® 5 Teflon Encapsulated Viton 6 Teflon Encapsulated Silicone 7 Buna N 8
SHAFT	Zirconia Ceramic 0 Hastalloy® C 1 Tungsten Carbide 2 Titanium 3 Monel® 5 316 Stainless Steel 6 Tantalum 7
IMPELLER	Nylon 1 Tefzel® 2
BEARING	Pennlon® 1 Tefzel 2 Teflon® 3

Series 200 Insert Style Matrix (sizes 3" and up)

**Electrical Cable for Standard Sensor Electronics**

- 20 feet of 2-conductor AWG 20 with AWG 22 drain wire shielded U.L. type PTLT wire provided for connection to display or transmitter unit. Rated to 105°C. May be extended to a maximum of 2000 feet with similar cable and insulation appropriate for application.

**Electrical Cable for IR Sensor Electronics**

- 48 inches of U.L. Style 116666 copper solid AWG 18 wire w/ direct burial insulation. Rated to 105°C.

Badger® and Data Industrial® is a registered trademark of Badger Meter, Inc.  
Chemraz® is a registered trademark of Greene Tweed of Delaware, Inc.  
Pennlon® is a registered trademark of Dixon Corporation.  
Hastalloy® is a registered trademark of The Haynes Stellite Company.  
Monel® is a registered trademark of Inco Alloys International, Inc.  
Kalrez®, Viton®, Teflon®, and Tefzel® are a registered trademarks of E.I. DuPont de Nemours and Company.  
Threadolet® is a registered trademark of Bonney Forge & Tool Works Corporation.

Due to continuous research, product improvements and enhancements, Badger Meter reserves the right to change product or system specifications without notice, except to the extent an outstanding contractual obligation exists.

**ETA Associates**  
 119 Foster Street, Bldg #6  
 Peabody, MA 01960  
 Tel: (978) 532-1330  
 Fax: (978) 532-7325  
 www.ETAassociates.com  
 eta@ETAassociates.com





**BadgerMeter, Inc.**  
 P.O. Box 581390, Tulsa, Oklahoma 74158  
 (918) 836-8411 / Fax: (918) 832-9962  
 www.badgermeter.com