

The Badger® Model 320 is a compact, programmable transmitter capable of converting the signal from Badger Meter flow sensors to scaled units (pulse signal). In addition to our standard square wave signal, it can also accept a sine wave making it a versatile transmitter for numerous applications.

With an onboard microcontroller and digital circuitry, the Model 320 is programmed from a Windows® based computer program. This eliminates the need to set dip switches, and produces precise, accurate, and drift free signals of high resolution.

The compact cast epoxy body measures 1.75" (44mm) x 2.75" (70mm) x 1" (25mm) and can easily be mounted to panels, DIN rails or enclosures. With multiple inputs, ease of use and a variety of enclosures, the Model 320 is a powerful and competitive transmitter for many of today's demanding applications.

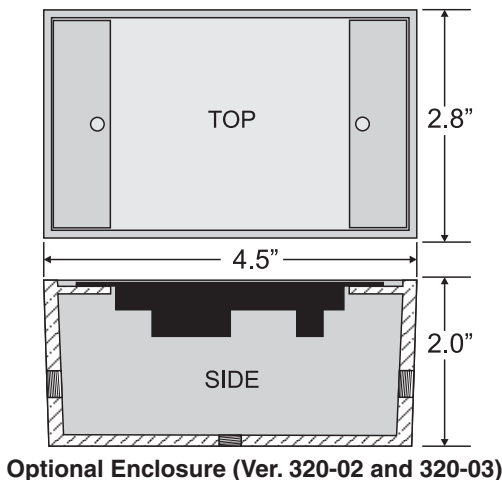
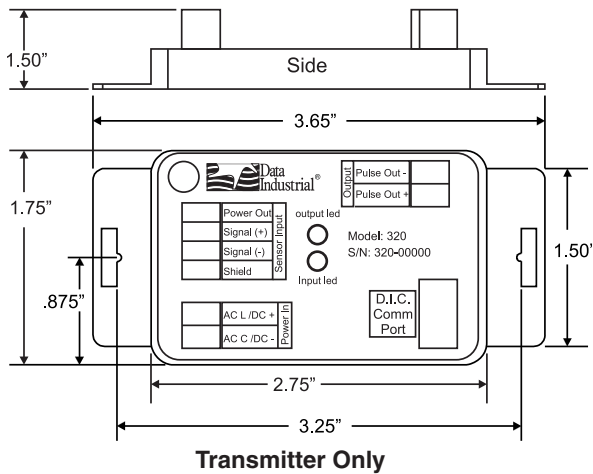

EXAMPLE: 320 - xx

SERIES	320	-	xx
Programmable Pulse Transmitter	320		
OPTIONS			
Transmitter Only			00
W / NEMA 4X Enclosure			01
W / Metal Enclosure			02
W / Plastic Enclosure			03
W / DIN rail Mounting Clips			04

320 Ordering Matrix

SPECIFICATIONS

Power

12-30VAC, 85mA max
12-40VDC, 30mA max
reverse and over voltage protected to 40VDC

Input Frequency

0.4 to 10 KHz

Transient Suppression

Complies with IEC-801-4 electrical burst, fast transient specification

Pulse Output

Isolated solid state switch in any standard or custom flow total units
Adjustable 50 mS to 1.0 second pulse output width in 50 mS increments
Maximum sinking current: 100mA @ 36 VDC

Temperature

Operating: -20 F to 158 F (-29 C to 70 C)
Storage: -40 F to 185 F (-40 C to 85 C)



PROGRAMMING

Units can be pre-set at our facility or easily programmed in the field. Field programming requires a Badger Meter Model A301-20 programming kit (consisting of a custom cable and software) and a PC running Windows®. In order to program, the Model 320 must be connected to power, and the Model A301-20 cable must be connected to a available 9-pin Com port on the computer.

Once the software is loaded and communications with the transmitter are established, the following parameters are entered in the setup screens:

1. Units of measure
2. K and Offset values - manually entered from values in sensor operators manual or automatically entered using the auto button
3. Units per output pulse
4. Filter setting
5. Pulse width

Once the values are set, the "send" command loads the transmitter.

All programming can be saved with a file name for later reference.

A full explanation of all settings is available through the software help file.

WIRING

Per standard wiring practices, the power must be off before making any wire connections. The terminal strips have removable plug-in connectors to make wiring easier.

1. Refer to Figure 1 for terminal connections.
2. Connect power supply positive (+) or AC Load to terminal marked AC L /DC +.
3. Connect power supply negative (-) or AC Common to terminal marked AC C /DC -.
4. Series 200 sensor, connect the red wire to Signal (+) terminal, black wire to Signal (-) terminal and the shield to Shield terminal (Disregard shield for the IR sensors).
5. Series 4000 sensor, connect the red wire to Power Out terminal, clear wire to Signal (+) terminal, black wire to Signal (-) terminal, and shield wire to Shield terminal.
6. If wiring to a sine wave output sensor consult factory.
7. Connect Pulse(+) from pulse input device to Pulse Out(+) of Model 320, connect Pulse(-) from pulse input device to Pulse Out(-) of Model 320.
8. For maximum EMI Protection, connect Model 320 ground lug to panel ground.
9. Ensure that all connections are tight, then plug connector into header.

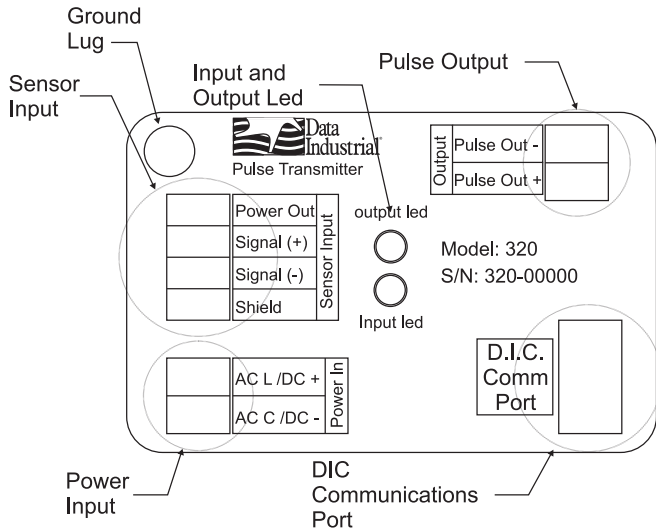

Figure 1: Model 320

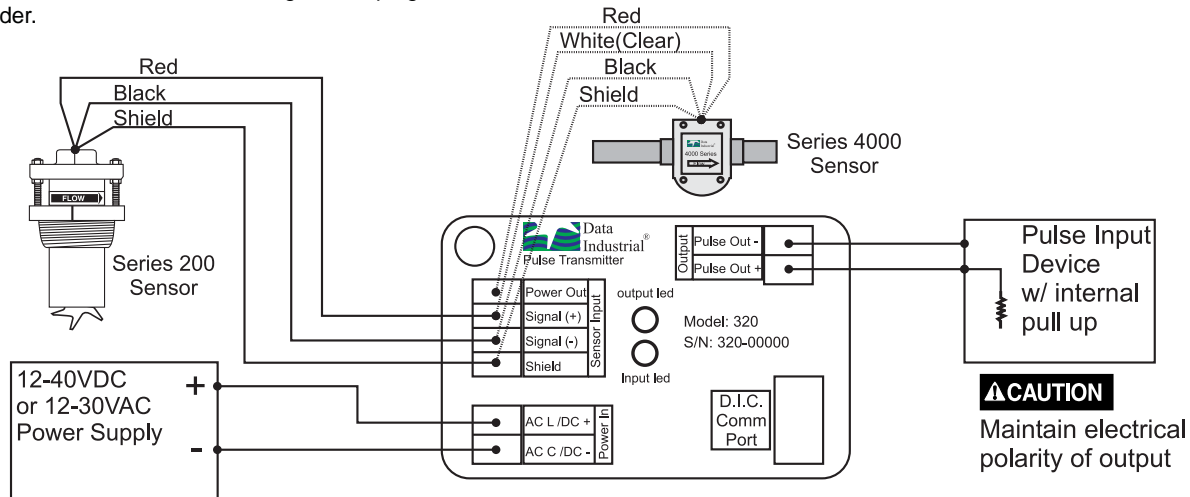

Figure 2: Wiring Model 320 to Series 200 or 4000 to a generic pulse input device

Badger® and Data Industrial® are registered trademarks of Badger Meter, Inc.
Windows® is a registered trademark of Microsoft Corporation.

ETA Associates
119 Foster Street, Bldg #6
Peabody, MA 01960
Tel: (978) 532-1330
Fax: (978) 532-7325
www.ETAassociates.com
eta@ETAassociates.com



Due to continuous research, product improvements and enhancements, Badger Meter reserves the right to change product or system specifications without notice, except to the extent an outstanding contractual obligation exists.



BadgerMeter, Inc.

P.O. Box 581390, Tulsa, Oklahoma 74158
(918) 836-8411 / Fax: (918) 832-9962
www.badgermeter.com