

RESISTANCE TEMPERATURE DEVICES (RTD'S)

#1	DESCRIPTION							
3	RTD							
	#2	ELEMENT TYPE [4, 9, 10, 11, 15, 18, 22] Platinum 0.00385 alpha ($\Omega/\Omega/^{\circ}\text{C}$)						
	B E P* S* X	Resistor Accuracy at 0°C	Thermometer Class [page 3-18]	Resistor Class [page 3-18]	Note: Wound or film resistors may be used. * For compliant results, use a 4wire RTD for high accuracy (types P & S).			
		± 0.3° C (Competitor's Std)	B	≥ F 0.30				
		± 0.15° C (JMS Standard)	A	≥ F 0.15				
		± 0.06° C	AA	≥ 1/2 F 0.10				
		± 0.03° C (Best Accuracy)	1/4 AA	≥ 1/10 F 0.10				
	#3	ELEMENT CONSTRUCTION [4] [3-11]						
	S D J K X	Single Dual Single Dual Other, specify	Standard construction Standard construction Swaged construction Swaged construction Other, specify	Note: Use swaged for high temperature, bendability, high vibration and/or longer than 6 ft.				
	#4	TUBE DIAMETER - MUST CHOOSE 1 FROM EACH COLUMN [5-30, 1-13, 1-14]						
	A B C D X Z	3/8" (.375") 1/4" (.250") 3/16" (.188") 1/8" (.125") Other, specify N/A	N K* M* O* R* W* Y*	Normal, closed tip (Standard) Pointed tip Weld pad Weld pad, removable (Fasttrax) Gas/Air, exposed Enlarged tip Reduced tip	Note: When selecting these options, a description must be provided. See 4-15 for example of removeable weld pad.			
	#5	TUBE MATERIAL [11, 12]						
	K L M C X	316 Stainless Steel 316 LSS I-600 (Use if symbol #7 >500°F) Teflon Coated, SS Other, specify						
	#6	LENGTH (L) (See sketches on Pg. 3-1 and 3-2 for L")						
	"	Immersion length in inches						
	#7	MAX. TEMPERATURE AT WHICH TIP WILL BE EXPOSED						
	A B* C* D* E*	Cryogenic Applications <200°C (392°F) =3 Teflon <285°C (550°F) =5 Kapton <350°C (662°F) =1 Fiberglass <660°C (1220°F) =4 HT Fiberglass			* If no transition (Z) is in symbol 13, we recommend these corresponding selections for primary wire insulation in symbol 10.			
	#8	STANDARD INDUSTRIAL ATTACHING DEVICE						
	W S M** A C D B E* F G H* I* J* K* L* H4 H6 N4 N6 S4 S6 C4** C6** X Z	Fixed NPT SS fitting - double threaded Spring-loaded NPT SS fitting - double threaded CSA explosion proof spring loaded fitting Spring loaded w/ threaded retainer Spring-loaded NPT SS fitting w/ oil ring - double threaded Spring-loaded SS fitting - single threaded Bayonet spring loaded assembly for thermowells & heads Adjustable spring over .250", .188", .125" sheath Reverse mounted steel plug fixed for attaching head Fixed stainless steel to sheath Compression fitting ss w/ ss ferrule Compression fitting ss w/ teflon ferrule Compression fitting ss w/ lava ferrule Compression fitting ss w/ nylon ferrule Compression fitting brass w/ brass ferrule 4" SS nipple-union-nipple (NUN4H1) 6" SS nipple-union-nipple (NUN6H1) 4" nipple-union-nipple (NUN4G1) 6" nipple-union-nipple (NUN6G1) 4" spring-loaded-union-nipple (NU4G1) 6" spring-loaded-union-nipple (NU6G1) 4" CSA certified flame path spring-loaded-union-nipple 6" CSA certified flame path spring-loaded-union-nipple Other, specify or if more than 1 is needed N/A (No fitting needed)					} See page 1-3 FOR MORE NIPPLE OPTIONS.	

[] BRACKETS INDICATE PAGE NUMBERS IN TECHNICAL CATALOG AVAILABLE ONLINE AT WWW.JMS-SE.COM/PDF/JMS_TECHNICAL_CATALOG.PDF

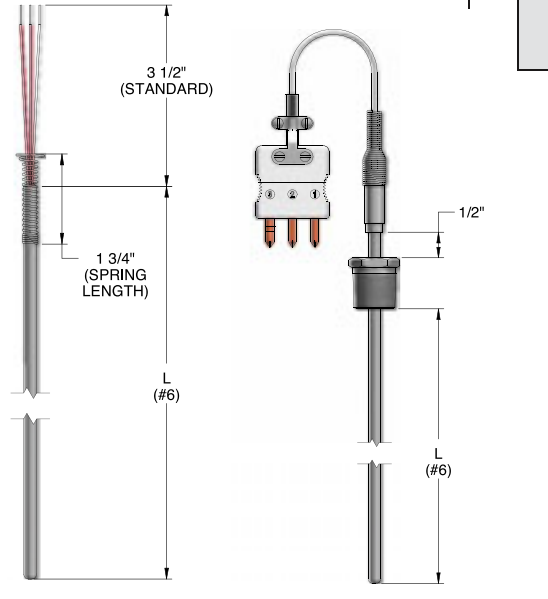

3	E	S	BN	K	12"	B	W
---	---	---	----	---	-----	---	---

* Length is calculated without consideration of these attaching device options. (See dwg on pg. 3-2).
 **CSA certified sensor must be assembled with thermowell bearing appropriate Canadian Registration Number (CRN).

RESISTANCE TEMPERATURE DEVICES (RTD'S)

#9	PROCESS NPT [1-3]		
L	1/8"		
M	1/4"		
P	1/2" (Standard w/ symbols W, S, & C above)		
O	3/4"		
X	Other, specify		
Z	N/A		
	#10	LEAD WIRE TYPE & LENGTH IN INCHES [SEE SECTION 7]	
	1	Fiberglass braid	Bare wire (Standard for swaged leads under 12") Other, specify N/A Note: All wire in tubes > 1/8" OD will be 24 AWG. Smaller tubes will have a max. of 28 AWG. If no transition or armor is specified, wire may be fragile. JMS standard lead wire for RTDs is stranded plated copper.
	2	PVC	
	3	Teflon (Standard)	
	4	Hi-temp glass braid	
	5	Kapton	
	6		X
	Z		Z
	#11	ARMOR OR HEAT SHRINK / JACKET [7-7]	
	A	3/16" ID SS flex armor (Standard)	G
	B	3/16" ID SS flex armor teflon coated white	H
	C	3/16" ID SS flex armor teflon coated black	J
	D	1/8" ID SS flex armor	Z
	F	SS overbraid	X
	#12	WIRE CONFIGURATION [17, 18]	
	T	2 Wire	
	Y	3 Wire	
	W	4 Wire	
	#13	TYPE OF TRANSITION [14]	
	H	Heat shrink	X
	S	Size on size	Z
	T	3/8" OD	
	R	1/4" OD	
	Q**	Cutttable (See full catalog)	
	M	M12 Fixed Mount Transition	
	#14	COLD END TERMINATION [SEE SECTION 6] Pick as many as applicable	
	A	Bare ends	8H
	B*	Miniature plug	8N
	C*	Standard plug	8S
	D*	Miniature jack	8I
	E*	Standard jack	8E
	F*	High temperature plug (< 800° F)	8D
	G*	High temperature jack (< 800° F)	8M
	I	Exp. proof NEMA 4X head, CSA & FM	Y
	K	Spade lugs (6SL)	X
	L	Aluminum head w/ hinged cover (6L / 6B4)	
	M	Aluminum head w/ screw cover & chain (6M / 6B4)	
	J	Explosion proof stainless steel NEMA 4X head, FM, CSA (6ISS/6B4)	
	P	Explosion proof AL head ATEX certified	
	U	Explosion proof stainless steel head ATEX certified.	
	N	Cast iron head w/ screw cover (6N / 6B4)	
	O	Open terminal block (6M)	
	Q	Black nylon Nema 4 head (6Q / 6B4)	
	R	High dome head (6R)	
	V**	Hermetic connector (6DC) - Male	
	WM**	Microphone style connector (6DA) - Male	
	WF**	Microphone style connector (6DA) - Female	
	#15	OPTIONS USE ONLY IF APPLICABLE [INTRODUCTION]	
	1*	Stainless steel tag	5
	2*	Plastic tag	6**
	3*	Paper tag	
	4*	Laser etch on probe	
		*Note: You must always specify information required on tag.	7
			8
		Calibrate at specified point(s). Corrections data will be provided for each point.	
		Calibrate specified temperature range. Corrections data will be provided for all temperatures within the range.	
		CE Marking [PAGE XV]	
		Bar Code	
		**Note: You must specify increments & range. (Ex. 0 to 300°F, 0.1° increments)	

LEAD WIRE

BARE ENDS

L (#6)

Immersion is overall length of tube for non-fixed attaching devices

P	3-36"	A	Y	T	A	1
---	-------	---	---	---	---	---

AVERAGING RTD'S

Continuous averaging resistance temperature detectors are most frequently used in air washing and air handling systems where turbulent and stratified air flow may effect the temperature measurement in a tip sensitive probe. The average temperature of the air in the duct can be measured with this type of sensor .

Any application which requires an averaging of temperature across an area would be suited for this sensor type. The operating temperature range for a continuous averaging RTD is from -100 to 400°F. Lower temperatures and temperatures up to 900°F are handled with a multipoint design (4, 8, or 16 points).

#1	DESCRIPTION									
3A	Averaging RTD									
	#2	Element Type 0.00385, 100Ω @ 0°C, Class B								
	E P4 P8	(-50° TO 275° F) Platinum 4 point, <900°F Platinum 8 point, <900°F	P16 X	Platinum 16 point, <900°F Other, specify			Note: Call the JMS Engineering Department for information about averaging thermocouples, swamp boxes and special proprietary multipoint designs.			
	#3	TUBE DIAMETER								
	B	1/4" (.250")	C	3/16" (.188")						
	#4	SENSING LENGTH								
	—	Sensing length in inches								
	#5	TUBE MATERIAL								
	K	316 Stainless Steel			F	Copper				
	#6	TOTAL PROBE LENGTH								
	—	Total probe length In inches								
	#7	STANDARD INDUSTRIAL FITTINGS								
	W B F G H I J K X Z	Fixed NPT ss fitting - double threaded. Sheath diameters less than 3/16", fittings are brazed to sheath. Bayonet spring loaded assembly for thermowells & heads Reverse mounted steel plug fixed to sheath for attaching head Fixed stainless steel to sheath Compression fitting ss w/ ss ferrule Compression fitting ss w/ teflon ferrule Compression fitting ss w/ lava ferrule Compression fitting ss w/ nylon ferrule Other, specify N/A (No fitting needed)							} For all compression fittings except fixed immersion is overall length of the tube.	
		Note: To specify extensions such as nipples, unions, couplings, use X and see pg 1-3 for complete part #.								
	#8	PROCESS NPT								
	L M P	1/8" 1/4" 1/2"	X Z	Other, specify N/A						
	#9	LEAD WIRE TYPE & LENGTH IN INCHES								
	1 3 6 7 8 9 10 X Z	Glass braid Teflon Glass braid / flex armor overall Teflon / flexible armor overall Glass braid / SS overbraid (3 wire only) 3 conductor teflon with overall jacket of teflon tape 3 conductor teflon / SS overbraid with overall jacket of teflon tape Other, specify No leadwire								
	#10	WIRE CONFIGURATION								
	T Y	2 Wire 3 Wire	W	4 Wire						
	#11	MAX SENSING TEMP								
	P Q	< 500° F > 500° F	Note: Q potting may not comply with ASTM megohm check.							

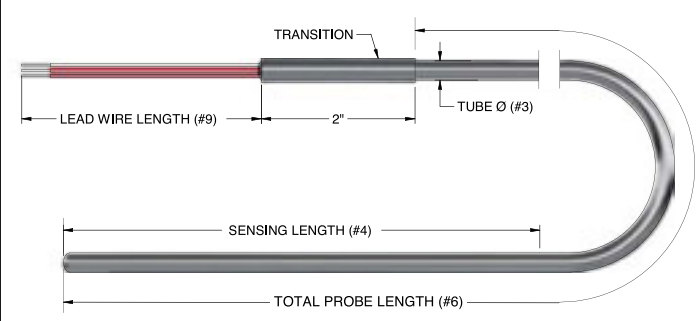

3A	E	B	12"	K	18"	I	M	3-36"	Y	P
----	---	---	-----	---	-----	---	---	-------	---	---

AVERAGING RTD'S

#12	COLD END TERMINATION [SEE SECTION 6] Pick as many as applicable		
A Bare ends B* Miniature plug C* Standard plug D* Miniature jack E* Standard jack F* High temperature plug (< 800° F) G* High temperature jack (< 800° F) I Explosion proof Nema 7 head (6I / 6PT) K Spade lugs (6SL) L Aluminum head w/ hinged cover (6L / 6B4) M Aluminum head w/ screw cover & chain (6M / 6B4) N Cast iron head w/ screw cover (6N / 6B4) O Open terminal block (6M) Q Black nylon Nema 4 head (6Q / 6B4)	R High dome head (6R) V Hermetic connector (6DC) - Male WM Microphone style connector (6DA) - Male WF Microphone style connector (6DA) - Female X Other, specify		
* We do not advise using these connectors for RTD's. Note: For any other cold end termination, use appropriate part numbers from section 6 in place of symbol #12.			
#13	TAGGING AND CALIBRATION OPTIONS (USE ONLY IF APPLICABLE)		
1* Stainless steel tag 2* Plastic tag 3* Paper tag 4* Laser etch on probe *Note: You must always specify information required on tag / laser etch.	5 7	Standard Room Temp Calibration. Due to the limited size of calibration chambers and the potential sensing length of these sensors, we recommend one point at room temperature. Please contact factory for any other calibration options. CE Marking [PAGE XV of online Technical Catalog]	

C	1
---	---

LOW COST AVERAGING RTD'S

Sense temperature of air streams in ducts and plenums. Sensors include a junction box with gasket to prevent leakage and vibration noise. These thermometers have a continuous element to sense true average temperature along their entire length. They provide accurate composite reading in locations where air may be stratified into hot and cold layers.

Rigid averaging sensors have a brass case. Bendable models have aluminum sheaths (copper on special order) formable to a radius of 4". Bendable sensors can criss-cross ducts to average temperatures in two dimensions.

Specifications:

Temperature range: -45.5 to 135° C (-50 to 275° F); Gasket: 100° C (212° F); Leadwire: 22awg, teflon insulated, 8" long; Sheath diameter: .188" OD.

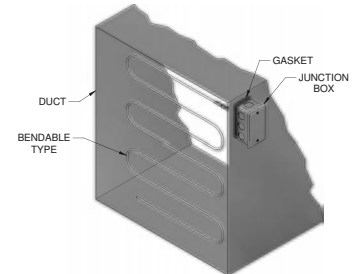

#1	DESCRIPTION			
3L	Platinum, 100 @ 0 C, a=.00385			
#2	SENSOR TYPE			
56	Rigid Sensor			
57	Bendable Sensor			
#3	WIRE CONFIGURATION			
T	2 Wire			
Y	3 Wire			
#4	INSERTION LENGTH			
_____ "	Length in inches (Standard Lengths for Rigid type (inches): 12", 18", 24", 48", 60", 72") (Standard Lengths for Bendable type (feet): 6 Ft, 12 Ft, 24 Ft)			
#5	OPTIONS			
A	Weatherproof connection box (2.12" W X 4.0" H X 1.75" D)			
B	Sensor only, no box			
C	Stainless steel tag			
X	Other			

3L	56	T	60"	A
----	----	---	-----	---

RTD WITH INTEGRAL PC PROGRAMMABLE TRANSMITTER

3-A RTD WITH 4-20 MA INTEGRAL OUTPUT

INDUSTRIAL STYLE INTEGRAL TRANSMITTER

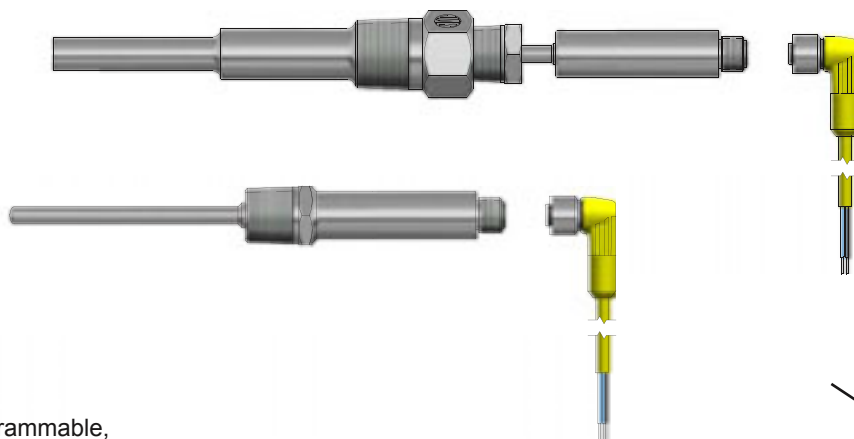

FEATURES:

- PC Programmable,
- NEMA 6P (IP68) rated with M12 connector.
- Ideal for most applications from -60 to 320 F .
- Ambient Temperature limits -40 to 185 F.
- Quick-n-Clean M12 connection for easy replacement.
- Carry a 4-20 mA to your PLC directly from the R TD with no special equipment.
- Available in fixed immersion and spring loaded for thermowells!!



ECONOMY HAND HELD INFRARED SENSOR

OPERATING INSTRUCTIONS

This thermometer is a non-contact infrared thermometer. Simply aim the thermometer at the target with the probe and press the measuring button to display the surface temperature. The distance to target diameter ratio (Distance:Spot) is 1:1 therefore the device should be positioned as close to the target as possible.

°C / °F:

The units of temperature indicated on the probe can be changed from °C to °F and back by pressing the pick hole under the back cover with a pointed object. The pick hole can be clearly identified as the hole on the opposite side of the probe from the indicator directly underneath the marking: °C / °F

BATTERY REPLACEMENT:

When an empty battery icon flashes in the LCD that indicates that the battery is low and should be replaced. Confirm that the power is OFF, loosen the cover at the top of the sensor in a counter-clockwise direction and replace the two LR44 1.5V cell batteries. Please remember to dispose of the batteries properly and to keep away from children.



To order, use JMS part number IR200

SPECIFICATIONS:

Measurement Range:	-33 to about 220° C (-27.4 to about 428° F).
Operating Range:	0 to about 50° C (32 to about 122° F)
Storage Range:	-20 to about 65° C (-4 to about 149° F)
Accuracy ($T_{amb} = 23^{\circ} C \pm 3^{\circ} C$)	$\pm 2\%$ of reading or $2^{\circ} C$ ($4^{\circ} F$) whichever is greater .
Resolution:	0.1° C / 0.1° F
Response Time:	1 second.
Emissivity Range:	0.95 fixed.
Auto switching off:	15 seconds.