

DM™ - Series Desiccant - Membrane Dryer

Compact Dryer Provides Moisture Protection For Portable Applications

- Removes only water vapor
- Continuous drying
- Low sample dew point
- No utilities needed
- Fast response time
- Rugged construction
- Excellent corrosion resistance
- Lightweight and portable

Perma Pure DM™-Series desiccant-membrane dryers are ideal for applications requiring portability. No power or purge gases are required, yet the compact-sized dryer removes water vapor from a flowing gas stream for hours, leaving other components in the gas unaffected. The dryer can be reused repeatedly and can be recharged in moments by replacing its desiccant.

Principle of Operation

Perma Pure's DM-Series gas dryers combine the selectivity of Nafion® with the simplicity of desiccant canister dryers. Gas sample flowing through the dryer contacts only Nafion tubing, which very selectively absorbs water vapor from the gas while quantitatively retaining the remaining sample components in the gas stream. Typically water passing through the Nafion tubing wall is carried away by a dry purge gas; in the DM-Series dryers, desiccant packed around the tubing absorbs the water.

The sample gas flows through a 24-inch strand of Nafion tubing with polypropylene monofilament braiding for protection. Water passing through the tubing wall is absorbed by a molecular sieve desiccant. Scattered crystals of indicating desiccant can be observed through the clear window to monitor the condition of the desiccant. The impact-resistant molded plastic case contains a snap-lock door for easy removal and replacement of desiccant. Luer and barb gas connections are standard. Other fittings are available on request.



Model Number	DM-060-24	DM-110-24
Flow Rate	Up to 500 mL/min.	Up to 1 L/min.
Drying Efficiency	Down to -30°C dew point	Down to -30°C dew point
Housing	Molded ABS, 4.2" x 2.4" x 1.0"	Molded ABS, 5.0" x 2.75" x 1.5"
Desiccant	4 Å molecular sieve	



PERMA PURE

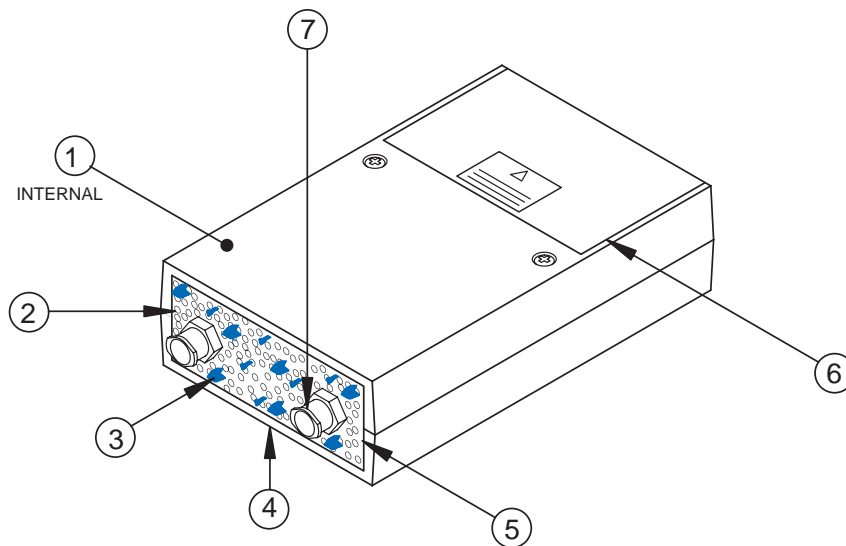

Figure #	Description
1	24" Nafion® tube dryer
2	Molecular sieve desiccant
3	Scattered crystals of indicating desiccant
4	Clear window
5	Molded ABS plastic case
6	Snap lock door
7	Gas connection fittings (Luers shown)

Sample Fittings

Both the DM-060 and DM-110 are supplied with the following fittings:

- Female luer fittings, mounted to the enclosure
- 1/8" barb adapter

An optional 1/8" tube compression fitting is available using part numbers DM-060-24-COMP-2 or DM-110-24-COMP-2

DM-Series Dryer Specifications

Model Number	DM-060-24	DM-110-24
Replacement Dryer	ME-060-24BB	ME-110-24BB
Replacement Desiccant	DM-AR	DM-AR
Desiccant	2.5 oz.	5.5 oz.
Housing	4.2" x 2.4" x 1.0"	5.0" x 2.75" x 1.5"
Dryer Tube Inner Diameter	0.052"	0.086"
Drying Per Charge	72 liters per desiccant refill	150 Liters per desiccant refill

DM™ is a Trademark of Perma Pure LLC, Nafion® is a Registered Trademark of E.I. DuPont.



ETA Associates

119 Foster Street, Bldg #6 • Peabody, MA 01960

Tel: (978) 532-1330 • Fax: (978) 532 7325 • www.ETAassociates.com • eta@ETAassociates.com