

SDS™-Series Supplemental Drying System

Boost Your Cooler Performance With A Supplemental Drying System

- Eliminates formation of acid mists
- Selective membrane technology
- Single or dual sample streams
- Improves chiller performance
- Corrosion resistant
- Improve sensitivity of IR measurements

SDS™ -Series Supplemental Drying Systems from Perma Pure provide a boost to an existing gas sample conditioning system. The SDS will reduce the dew point of the sample from +4°C down below -15°C, reducing the total moisture content by an additional 80%. Reducing the gas sample dew point is essential in order to eliminate the formation of acid mists. Rather than replace an existing cooler with a “super” cooler, the SDS is a cost effective way of extending the life and improving the performance of your existing sample conditioning system.

Infrared analysis of CO and SO₂ is very susceptible to moisture interference, as are measurements of low ppm concentrations of NO_x and H₂S. It is desirable to remove as much moisture as possible. In these applications, installing the SDS downstream of your conditioning system is an effective and less expensive alternative to a complex subzero cooler.

Principle of Operation

Proven tube-in-shell membrane technology is the basis of the SDS-Series drying system, which selectively removes water vapor from a gas stream. The driving force is the vapor pressure differential between the sample gas and a purge gas counterflowed outside the tubing. This difference drives the reaction, quickly drying the gas stream.

The SDS-Series drying system is designed as an add on to an existing conditioning system. It can also be used as the primary gas drying device, provided the sample is non-condensing at ambient temperature. It is equipped with 4 mounting holes and 1/4” compression gas connection fittings. The inlet gas stream should be non-condensing at ambient conditions. The system requires a purge gas supply of 2 times the sample flow rate.

The SDS can handle one stream of up to 10 lpm, or two streams of up to 5 lpm each.



Model Number	4C-D201	4C-D202
Flow Rate	5 LPM max.	10 LPM max.
Enclosure	NEMA 12, IP54, Gray powdercoated finish 24" x 6" x 6" HWD	
Inlet Humidity	Non-condensing at room temperature	
Outlet Humidity	<-15°C dew point at maximum inlet flow and humidity conditions	
Max. Pressure	80 psig	

4C-D201 and 4C-D202 Specifications

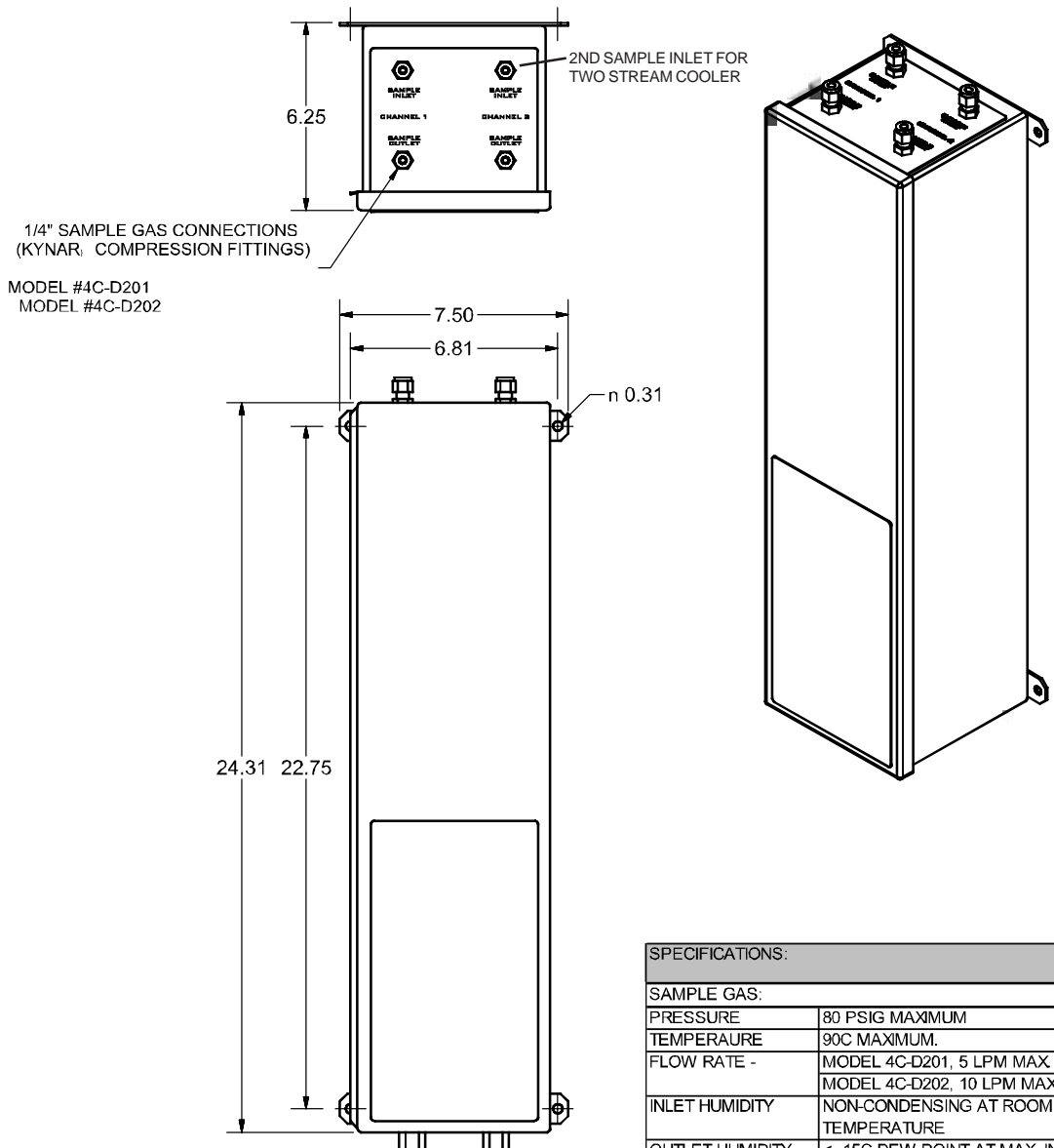

1/4" SAMPLE GAS CONNECTIONS (KYNAR, COMPRESSION FITTINGS)

MODEL #4C-D201
MODEL #4C-D202

SPECIFICATIONS:	
SAMPLE GAS:	
PRESSURE	80 PSIG MAXIMUM
TEMPERAURE	90C MAXIMUM.
FLOW RATE -	MODEL 4C-D201, 5 LPM MAX MODEL 4C-D202, 10 LPM MAX
INLET HUMIDITY	NON-CONDENSING AT ROOM TEMPERATURE
OUTLET HUMIDITY:	< -15C DEW POINT AT MAX INLET FLOW AND HUMIDITY CONDITIONS
PURGE AIR:	
PRESSURE	30 - 150 PSIG
HUMIDITY	< MINUS 40C DEW POINT
OTHER	OIL-FREE

PURGE AIR INLET,
1/4" NPT FEMALE
(30-150 PSI, -40C DEW POINT
INSTRUMENT AIR REQUIRED)

PURGE AIR EXHAUST
1/4" NPT FEMALE
ALLOWS FOR CONNECTION
TO OUTSIDE VENT
(CONNECTION NOT REQUIRED)



ETA Associates

119 Foster Street, Bldg #6 • Peabody, MA 01960

Tel: (978) 532-1330 • Fax: (978) 532 7325 • www.ETAassociates.com • eta@ETAAssociates.com