

HALOGUARD® III

Cost-effective, Photoacoustic Infrared Monitoring for Wide Area Applications



Complete
Submittal Information

Available at:

www.thermalgas.com

**Photoacoustic IR
Technology Enhances
Selectivity & Sensitivity
for:**

- Refrigeration Equipment
- Machinery Rooms
- Cold Storage Areas
- Process Cooling
- Provides low ppm detection for all refrigerants. Optionally reports oxygen depletion.
- Meets ASHRAE Std. 15, in addition to mechanical, fire & building codes
- Single or multigas
- Single or multipoint sensing
- Alerts service personnel
- Features remote notification
- Upgradeable to newer refrigerants
- Reduces refrigerant loss
- Controls exposure risk

THERMAL GAS *Systems* inc.

Haloguard® Monitors

HALOGUARD

III

Cost-effective, 20 ppm Photoacoustic Infrared 24 Hour Leak Detection & Notification

The HALOGUARD III combines advanced microprocessor based digital signal processing and a wideband photoacoustic infrared cell to provide the newest most advanced system for continuous monitoring of all refrigerant gases.

The HALOGUARD III monitors single or multiple, local and remote locations and provides notification when gas concentration reaches preset alarm levels. Up to 24 different gases may be monitored simultaneously by adding optional channel scanners and remote IR modules.

Alarm relays and analog outputs are designed to activate remote devices or to interface with an energy management (EMS) or building automation (BAS) system.

To find out more, contact Thermal Gas Systems today.

Features

- Simple installation
- **Easy field calibration**
- Up to 500 ft. sample draw
- Three user alarms adjustable between 50 ppm & 100% of scale
- LCD shows PPM Concentration, Alarm, Test, Reset, and Fault Diagnostics
- **Three flashing alarm LED's**
- Fault, Ready & Power ON/OFF LED's
- Analog output for BAS/EMS interface or data logging
- Four alarm relays for ventilation, damper or remote notification
- Alarm Test & Reset/Silence push buttons
- High-intensity audible alarm
- Rugged enclosure

Options

- 2, 4 or 8 channel scanner
- Remote IR module
- Amber strobe light alarm
- Remote strobe light & horn alarms
- Gas calibration kit
- NEMA 4/12 enclosure
- Oxygen depletion sensor

Specifications

Technology.....	Photoacoustic infrared
Electrical Supply.....	115-230V, 50-60Hz, 65W
Fuse.....	3A/240V, fast acting
Output Signal	Std: 4 x 5A, dry contact relay SPDT Opt: 7 x 5A, dry contact relay SPDT Opt: 0-5 VDC, 4-20mA analog
Sensitivity.....	20 ppm
Resolution.....	1 ppm
Measuring Range.....	0 - 1000 ppm all refrigerants
Response Time.....	<1 minute per channel
Clearing Time.....	<3 minutes per channel
Maximum Sample Point Tubing Length.....	150' with standard performance. 500' optional where slower response is acceptable.
Operating Conditions.	30°F to +120°F non-condensing
Enclosure:	Weight:
	Std:NEMA 250..... 20 lbs
	Opt: NEMA 4/12.. 25 lbs
Sample Rate.....	1.0 lpm
Listed to UL 3111-1 and CAN/CSA-C22.2 No. 1010.1-92	



Warranty

HALOGUARD III is guaranteed for one year from the date of shipment. Any device found defective in that period will be repaired or replaced free of charge. Read terms and conditions of sale for complete warranty information.

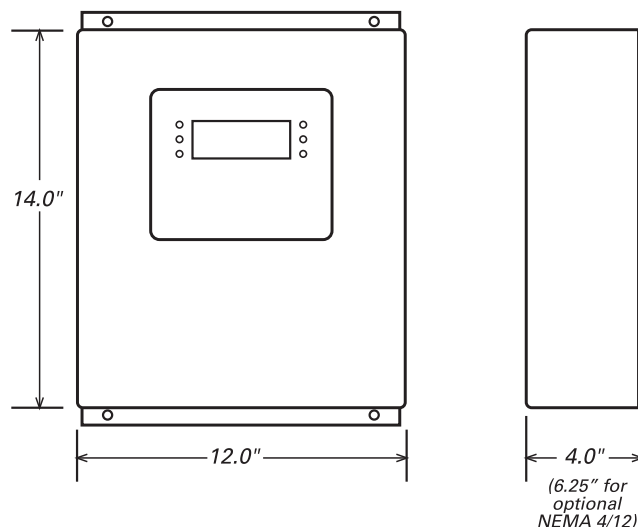

ETA Associates
119 Foster Street, Bldg #6
Peabody, MA 01960
Tel: (978) 532-1330
Fax: (978) 532-7325
www.ETAassociates.com
eta@ETAassociates.com